

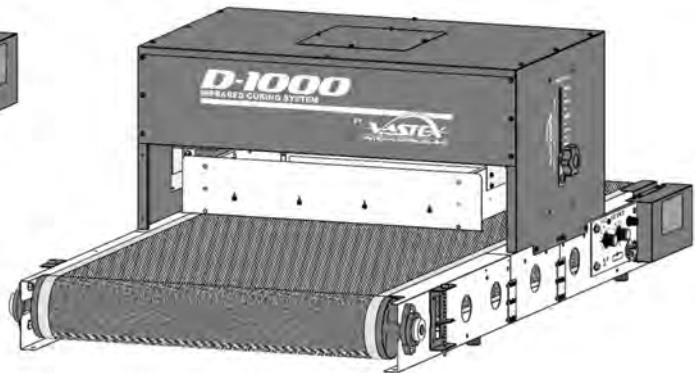

D-100 and D-1000 Series Dryer

Assembly and Operating Instructions

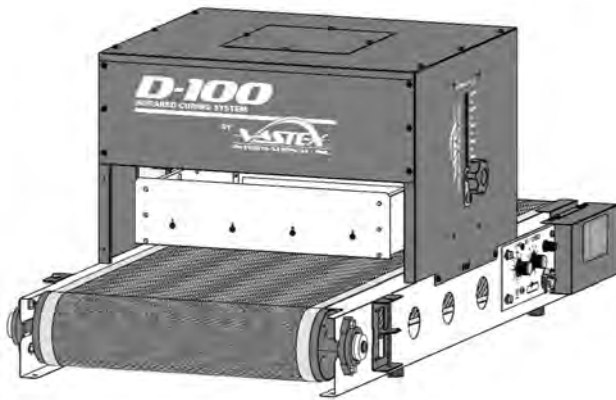

Contents	Page#
• Safety Information	2
• General Information	3
• Package Contents	4-5
• Component Identification	6
• Assembly	7-14
• Belt Tracking	15
• Electrical Requirements/Controls	16
• Operation	17
• Chain Drive Adjustment	18

Vastex International, Inc.
 7 Emery Street
 Bethlehem, PA 18015-1982 USA
 Phone# 610 625-2702 Fax# 610 625-2775
 Web Site www.vastex.com

Authorized Representative in Europe:
 Certification Experts BV
 Nieuwstad 100 1381 CE Weesp,
 The Netherlands
 Tel : + 31 (0) 294 – 48 33 55
 Fax : + 31 (0) 294 – 41 46 87

Vastex E-mail assistance
 Purchasing, product and printing Info:
sales@vastex.com
 Electrical Support:
stech@vastex.com
 Tech Support, Mechanical Setup, and Operation:
techsupport@vastex.com

Electrical Drawing #: _____ Rev: _____

Serial Number: VTX _____ Date: ___/___/___

(Please log your machine's serial number and date of purchase for future reference.)

Introduction

Congratulations, you have chosen a VASTEX conveyor curing system. VASTEX has been designing and building dryers since 1960 and has the knowledge and expertise to supply a quality dryer and help you keep it running for years to come. VASTEX has innovated many of the features found in conveyor ovens today from control methods, modular features, air movements and belt tracking.

Vastex Infrared Dryer have been Factory tested and burned in for a period of 2-8 hours. All components are tested to be sure they work correctly when the Dryer leaves our factory.

Inspect all packages and notify the shipping company if any damages are detected.

Safety

The Instruction Manual and Safety Instructions must be read and understood by anyone operating the Vastex Conveyor Drying System.

- The operator should read and understand the instruction manual before operating this equipment. Store instruction manual and safety instructions near equipment for easy access to operators.
- VASTEX Conveyor Drying System is intended for the curing of non-flammable inks on screen printed materials. Do not use for any other purpose unless authorized by Vastex International, Inc. Use of this equipment for any other purpose can be dangerous and may cause damage to this equipment, voiding the warranty.
- It is recommended that the area around this equipment be designated as a work area and only authorized employees be allowed in the area.
- Children and pets must be kept clear of the work area.
- Do not place any objects on top of the drying chamber. Surfaces are hot!
- Never leave equipment unattended.
- Do not operate conveyor or dryer with any cover or guard removed.
- Operator must be familiar with controls of the dryer and conveyor.
- Never put excessive load on the conveyor belt.
- Before starting production, the operator must check that all covers and guards are in place, no material has been left on the conveyor, and the work area is clear of obstructions.
- Switch on and verify conveyor belt is moving before turning on the heat.
- Allow dryer to cool to 300°F (149°C) or turn off heat for 10 to 15 minutes before switching off conveyor.
- Always turn off power at the main disconnect at the end of production.
- In case an abnormal symptom occurs, for example excessive vibration, noise, and strong smell or smoke development, turn off the VASTEX Conveyor Curing System and contact a qualified technician.
- Immediately turn off the VASTEX Conveyor Curing System if products become jammed in the drying chamber or conveyor belt.
- Do not remove any cover or guard until power at the main disconnect is switched off and locked out. No unauthorized persons are to be allowed inside the control boxes.
- Turn off and lock out power at the main disconnect before any cleaning or maintenance.
- Only qualified technicians should be allowed to make repairs on the VASTEX Conveyor Drying System.

Stability during use, transportation, assembly, testing, and foreseeable break-

The D-100 and D-1000 dryers are designed and expected to be inherently stable under all foreseeable conditions of use, assembly, testing, etc., so long as the procedures listed in this manual are followed. Be certain that your workbench, table, or stand can safely support the weight of your machine (see below).

Safe handling, transport, and storage:

Unplug your dryer and allow it to cool before storing. When handling or transporting your machinery, be aware of the following weights and dimensions:

D-100: Assembled — 89 lbs (40.4 kg); 46" x 24" x 24" (119 x 61 x 61 cm)
Boxes: #1 – 57 lbs (25.9 kg); #2 – 14 lbs (6.4 kg); #3 – 18 lbs (8.2 kg); Boxes on skid: 115 lbs (52.2 kg)

D-1000: Assembled — 116 lbs (52.6 kg), 46" x 32" x 24" (119 x 81 x 61 cm)
Boxes: #1 – 38 lbs (17.2 kg); #2 – 43 lbs (19.5 kg); #3 – 35 lbs (15.9 kg); Boxes on skid: 137 lbs (62.1 kg)

Safety during adjustment and maintenance

Before beginning any maintenance or adjustment procedures on your dryer:

- If the machine's heater has been ON, shut the heat control OFF, but allow the belt to continue running for 10 -15 minutes, or until the heater has cooled to 300°F (149°C) or lower . If the belt is stopped while the heater is hot, belt damage will occur.
- Switch machine OFF and disconnect from power before beginning any adjustment or maintenance.
- Do not attempt any maintenance while machine is powered.
- Do not run machine with panels or guards removed.

Adjustment and Maintenance:

- Periodically check ink temperature on garments exiting machine. See page 11, "Operation Tips." Readjust temperature control as necessary to maintain correct temperature for your application.
- Occasionally, check belt tracking and adjust if necessary. See page 9, step 12.
- Chains in chain drives can loosen over time; occasionally check the tension on the chain in your machine.

In the event of a malfunction or breakdown:

- Allow heater to cool, then shut off machine and disconnect from power as described above in "Safety during adjustment and maintenance."
- Follow the troubleshooting chart below
- If the chart does not resolve the trouble, contact Vastex for additional assistance.

Symptom	Possible Cause	Solution
No functions operate	Machine unplugged Building wiring fault	Make sure machine is plugged in. Have wiring checked.
Belt does not move	Belt circuit fuse(s) blown Speed control faulty Belt motor faulty	Check or replace fuse(s). Replace. Contact Vastex. Replace. Contact Vastex.
No heat	Faulty heater control Faulty heater assembly	Replace. Contact Vastex. Replace. Contact Vastex.

Package Contents D-100 only

3 Separate Cartons

Carton #1 Conveyor Components

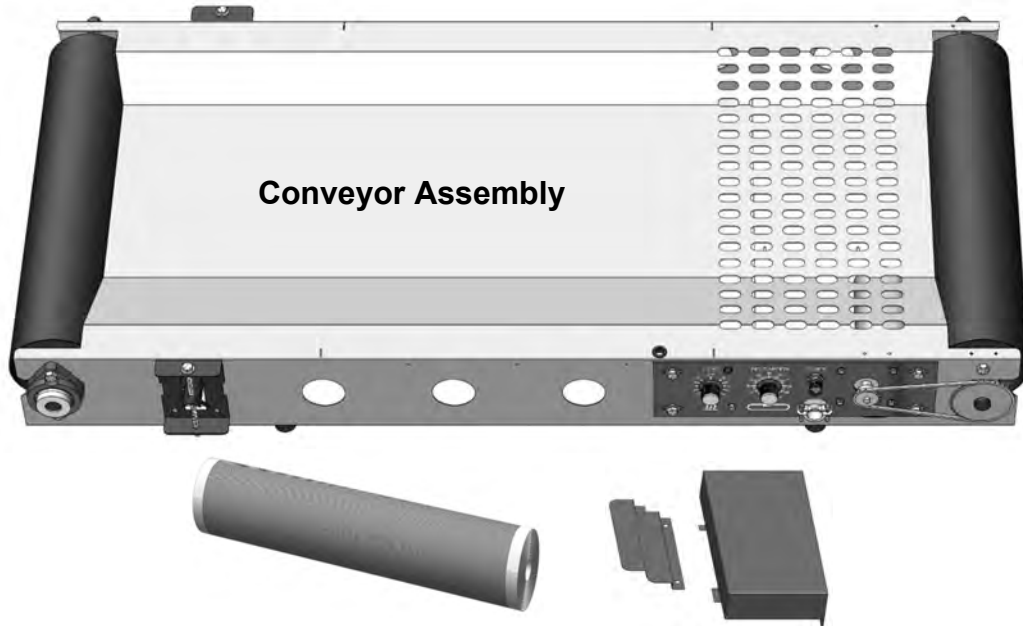

Additional items in Carton #1
 1) Belt, 1) Chain guard, and 1) Hardware package with: 6 screws and 2 belt guards.

*Hardware not show

Carton #2 16 x 16 Infrared Heater



Carton #3 Chamber Components

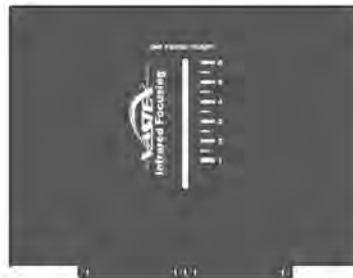

Side Panel



Side Panel



Back Panel



Heater Hangers
Brackets



Front Panel



Exhaust
Cover



Heater Hold
Down Tabs



Knobs



Wire Cover

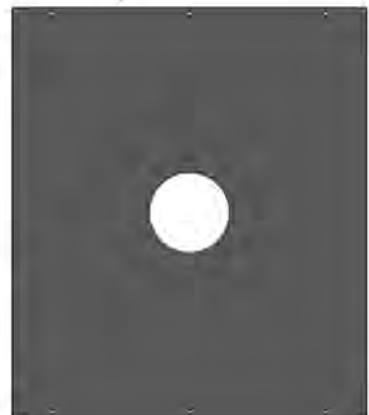

Top Cover

Carton #3 Hardware Package Contains

- (1) Wire Cover
- (2) Knobs
- (2) Heater Hold Down Tab
- (2) Heater Hanger Bracket
- (40) Black #8 Sheet Mtl Screws
- (1) 1/4" & 7/16" Hex Wrench

*Hardware not show

Package Contents D-1000 only

5 Separate Cartons

Carton #1 Front Conveyor Components

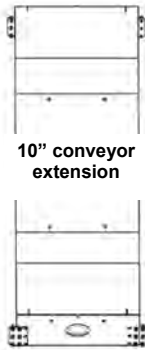
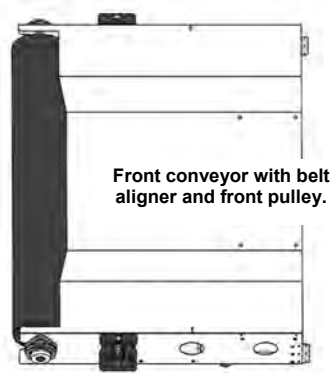

Carton #2 Rear Conveyor Components

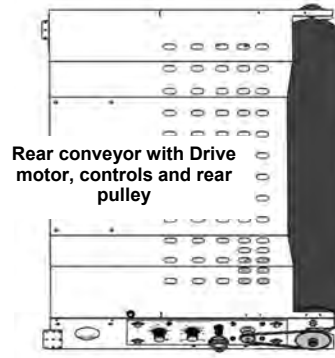

Additional items in Carton #3
 1) Belt, 1) Chain guard, and 1) Hardware package with: 6 screws and 2 belt guards.

*Hardware not show

Carton #3 10" Conveyor Extension Components

Carton #4 16 x 20 Infrared Heater



Carton #5 Chamber Components

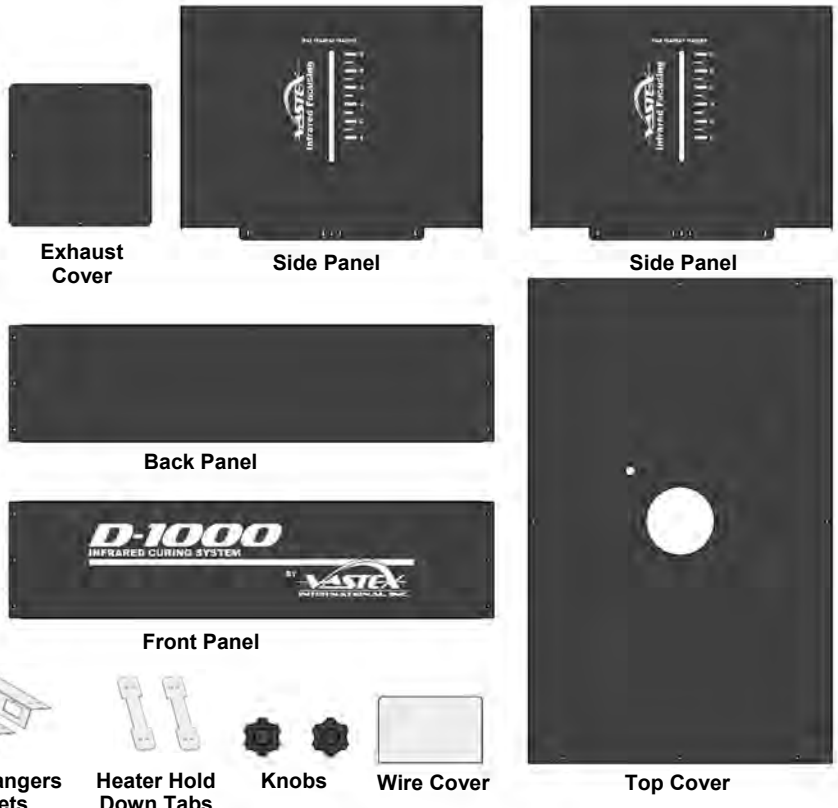

Carton #5 Hardware Package Contains

- (1) Wire Cover
- (2) Knobs
- (2) Heater Hold Down Tab
- (2) Heater Hanger Bracket
- (40) Black #8 Sheet Mtl Screws
- (1) 1/4" & 7/16" Hex Wrench

*Hardware not show

Component Identification

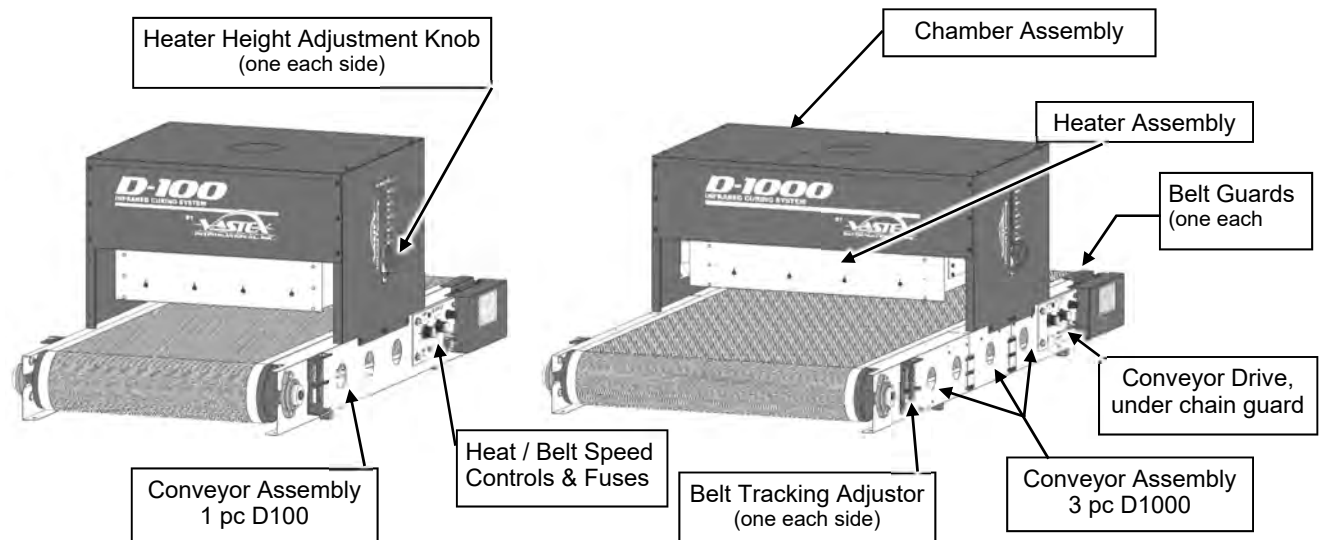

Chamber Components

IR Heater

HI-16-D100-120
 HI-16-D100-240
 HI-1620-D1000-120
 HI-1620-D1000-240

The infrared heaters in VASTEX dryers emit medium wave infrared heat, perfect for curing many types of fabric inks. The heater height and tilt is adjusted by knobs located on the sides of the chamber. A heater height scale allows for accurate height adjustment.

Conveyor Components

Belt

D100 p/n 04-06-065
 D1000 p/n 04-06-131
 D1000 extension belt
 p/n 04-06-132

The conveyor belt is made of Teflon coated fiberglass. It is joined together with an alligator lace using a steel pin to connect each side. The belt will not burn under normal conditions but the dryer should always have the belt moving while the heater is hot. The belt should remain tracked in the center of each pulley. (See Belt Installation and Tracking for adjustment instructions.)

Aligner

The aligner is a device for tracking the belt and keeping it on the pulley. As the belt moves from side to side the aligner is used for adjustments to keep it centered. The belt does not have to be perfectly centered on the pulley but should not be hanging over either edge.

Pulley

The pulleys at either end of the conveyor are made by VASTEX of 4 1/2 inch tubing with 3/4 inch center shaft. They are mounted on self aligning flange bearing blocks for precision rolling.

Gear Motor

P/N 04-02-005

A 90 Volt DC gear motor is located to the rear of the conveyor. It drives the rear pulley and belt with a roller and a #25 chain.

Belt Speed Control

P/N 04-01-004 (120V)
 P/N 04-01-005 (240V)

Rotate knob clockwise to increase, counter clockwise to decrease belt speed. Turn knob counter clockwise until it clicks for off position.

Heat Control

P/N 04-01-008 (120V)
 P/N 04-01-009 (240V)

Turns power on/off and varies heater temperature.

Fuses

P/N 04-03-057
 (Fuse AGC 1 amp)

Protects the belt drive control circuit.
 One required for 120V Dryers, two required for 240V Dryers

Assembly D1000 Conveyor Only

The D1000 conveyor comes in three sections. Slide them together while interlocking the joiner plates and insert six (6) screws on each side as shown below.



Do not plug in the conveyor until after the chamber is completely installed.

- 1) Slide the (3) conveyor pieces together.

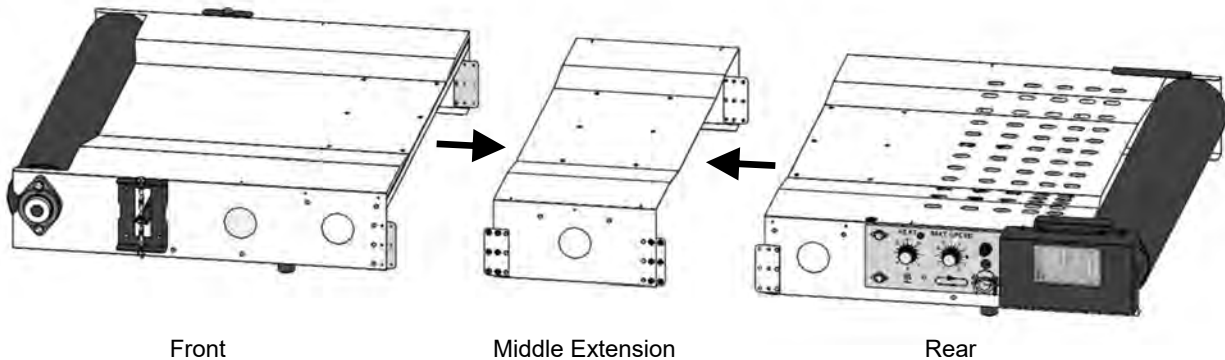

- 2) Fasten the conveyor pieces together with (6) black sheet metal screws. Each section has a connection on both sides of the conveyor.

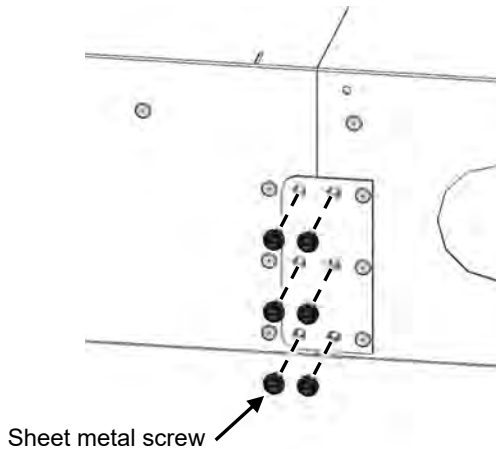

- 3) Finished conveyor will look as shown.

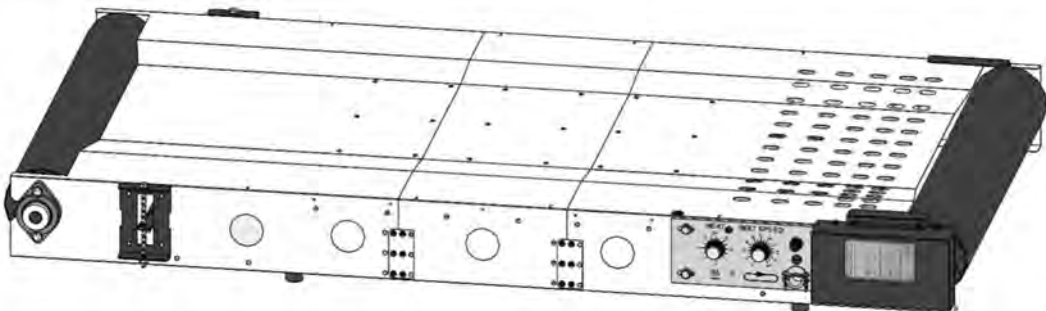

Assembly

- 1) Install a Heater Knob in to both chamber side panels. Each chamber side will come with the Heater Mount pre installed.

NOTE: Make sure the Pointer and Weld Nut line up before installing the Heater Knob.

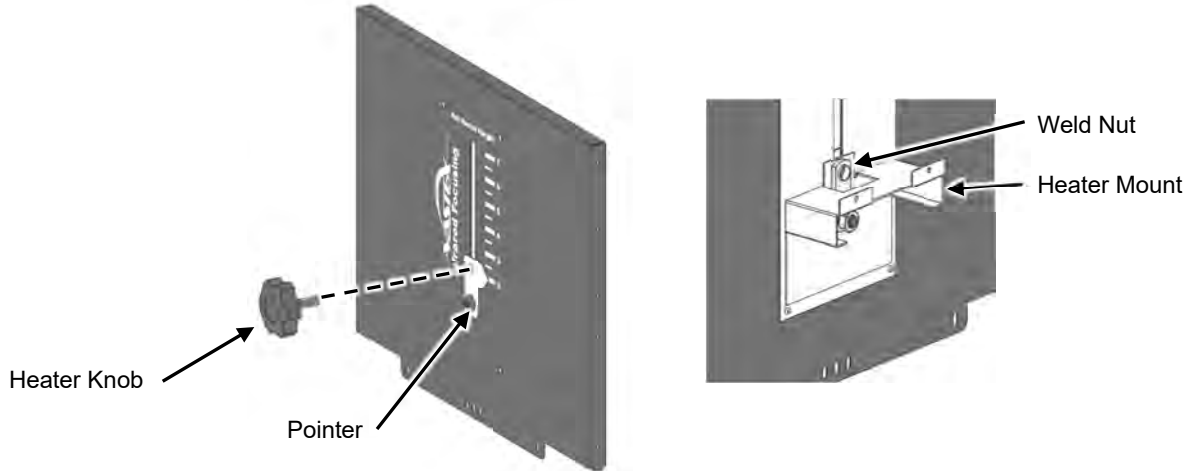

- 2) Install the Front and Rear Panel to one of the Side Panels with (6) black sheet metal screws.

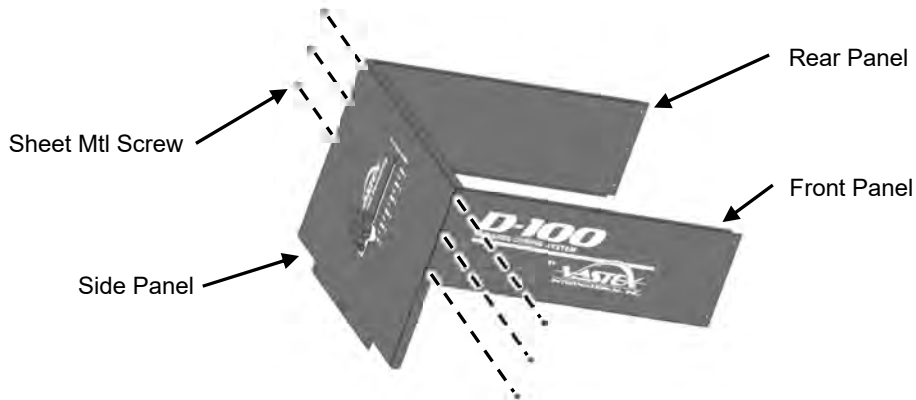

- 3) Install the opposite Side Panel to the Front and Rear Panels with (6) sheet metal screws.

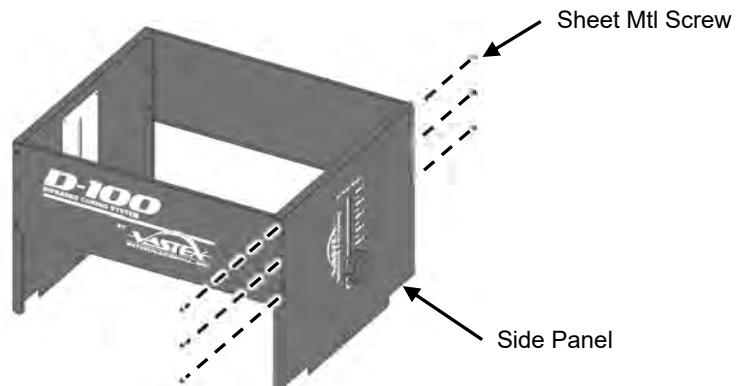

Assembly Continued

- 4) Install a Heater Hanger on to each side of the Heater using (4) black sheet metal screws. Be sure to use the top set of holes on the side of the heater.

NOTE: If you desire to have your heater height 1"(25.4mm) higher than the scale on the side of the chamber use the bottom set of holes.

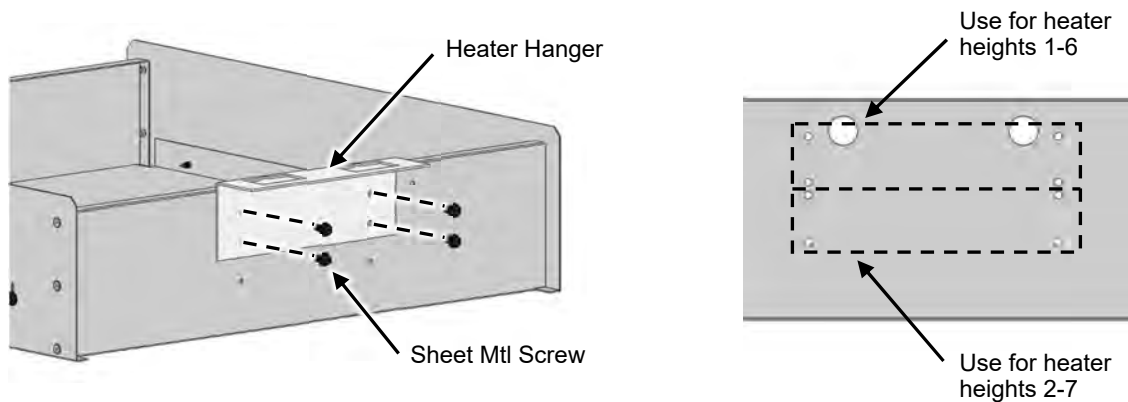

- 5) Lay the assembled heater into the chamber. The tabs pointing up on the Heater Mounts will fit into the openings on the Heater Hanger. Make sure to have the heater wires on the right side of the chamber.

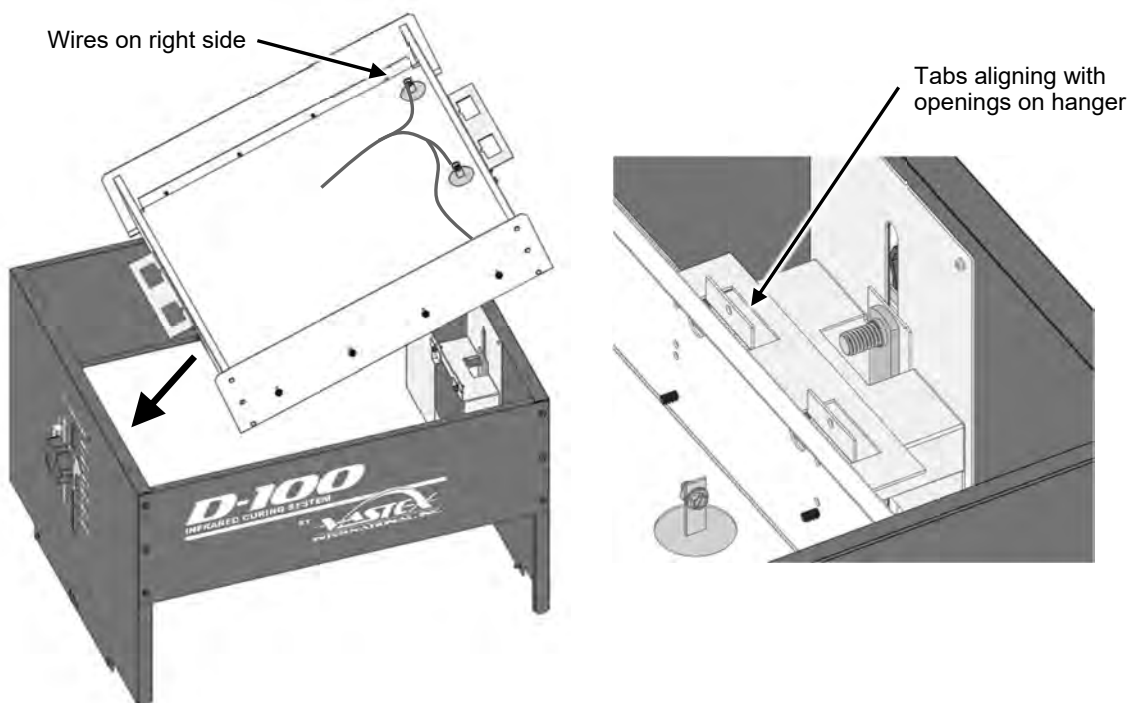

Assembly Continued

- 6) Install a the Heater Hold Down on each side of the heater using (2) black sheet metal screws.

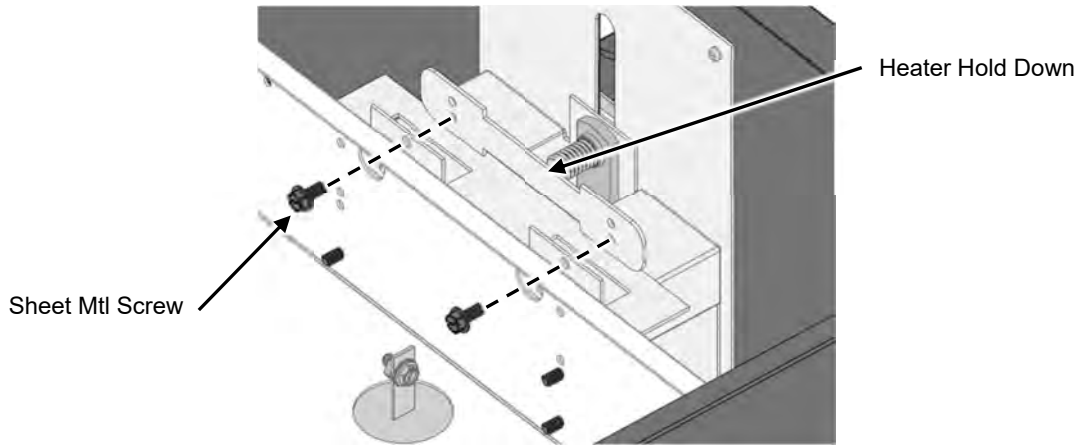

- 7) Place the chamber on to the conveyor. The bottom of the chamber has tabs that fit into slots on the conveyor.

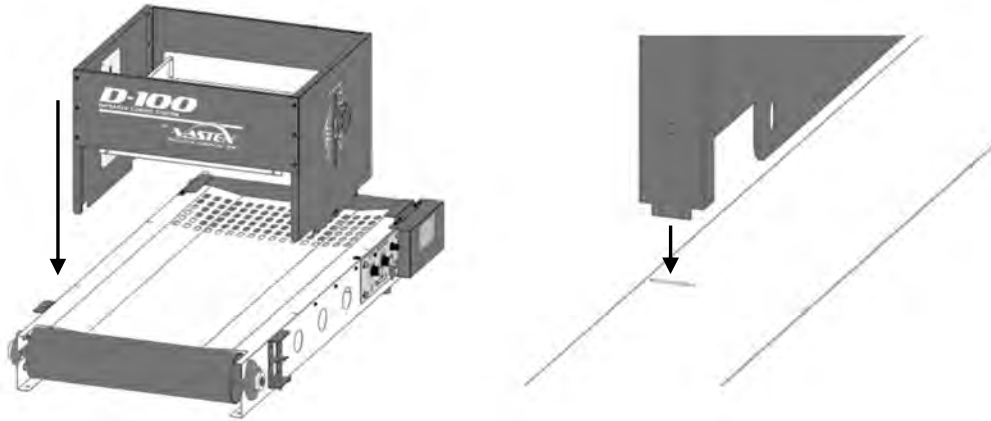

- 8) Fasten the chamber to the conveyor with (6) black sheet metal screws, (3) per side.

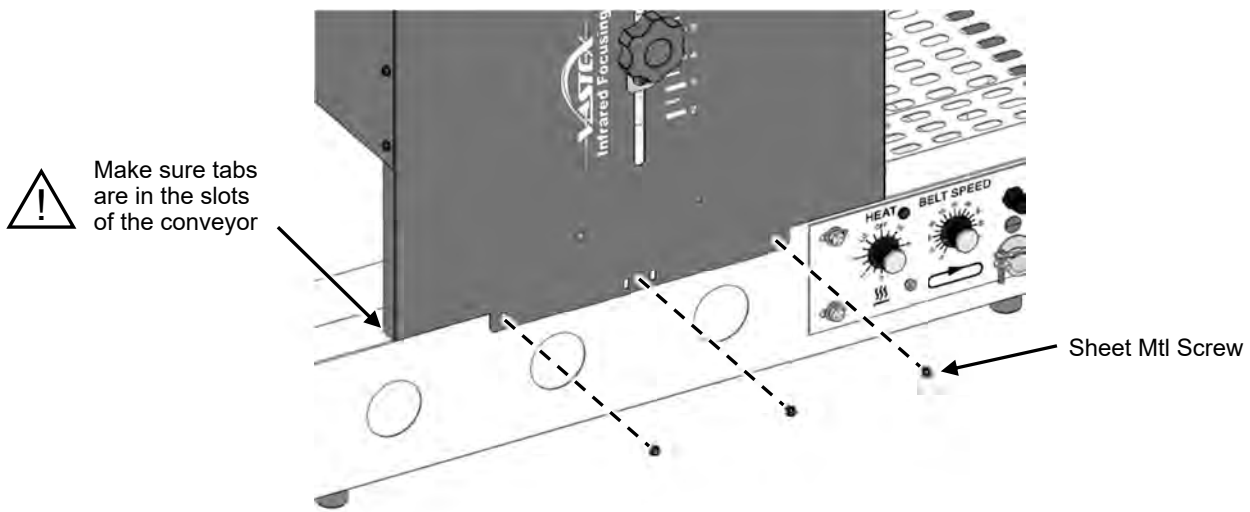

Assembly Continued



Be sure the machine is unplugged

- 9) The three wires out from the conveyor will have caps on the ends of the wires. Remove the caps before moving on to the next step

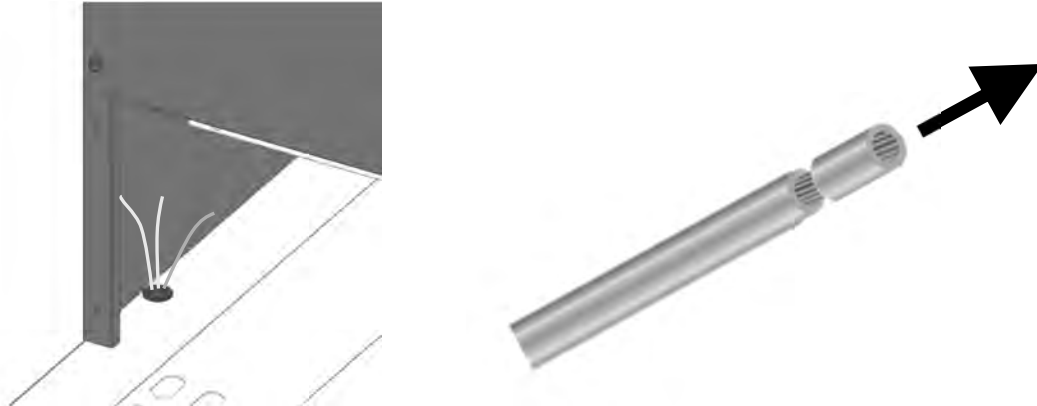

- 10) The three wires, two white and one green, will have in-line Wago connectors pre installed from the factory on the heater. Match the white wires from the heater to the white wires coming from the conveyor, and the same for the green wire. It does not matter which white wires go together, but the green wires must go together! Be sure to push the wire all the way into the Wago until it stops, then close the latch.

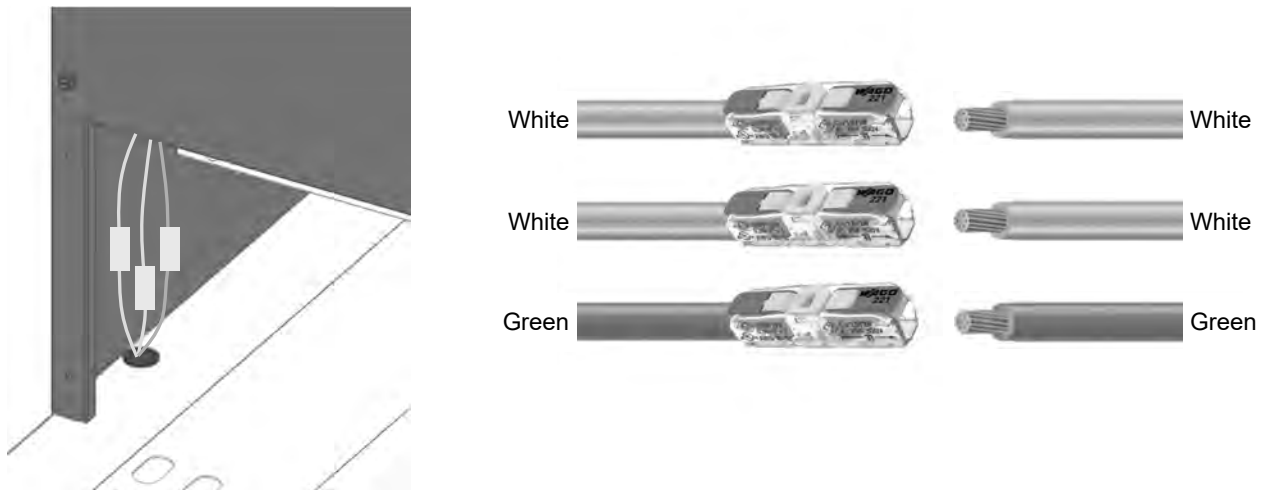

- 11) There will be a piece of black insulating tube on the wires. Slip the tubing over the bundle of in-line Wago connectors for an added layer of heat protection.

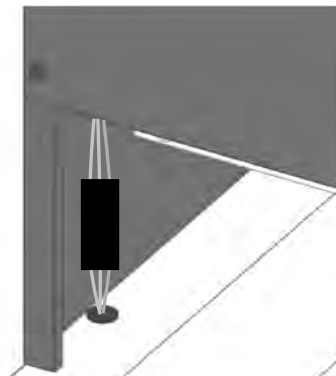

Assembly Continued

12) Install the wire cover with (2) black sheet metal screws. Make sure all the wires are behind the cover.

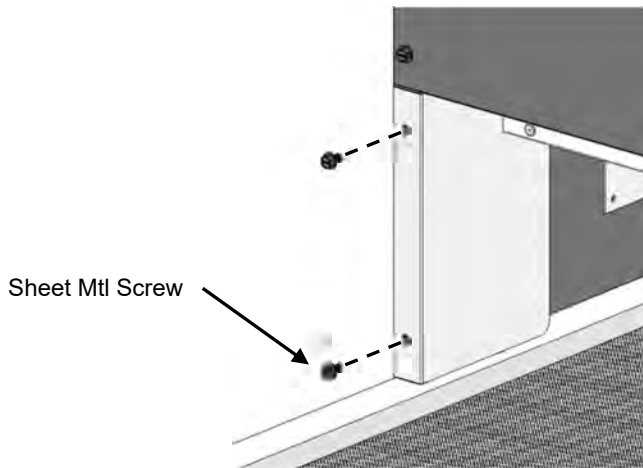

13) Carefully lay the dryer on to its side.

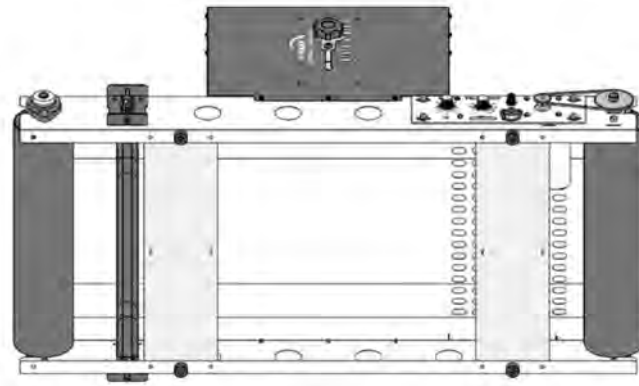

14) With the dryer still on its side, pass the belt over the aligner bar and both bottom braces.

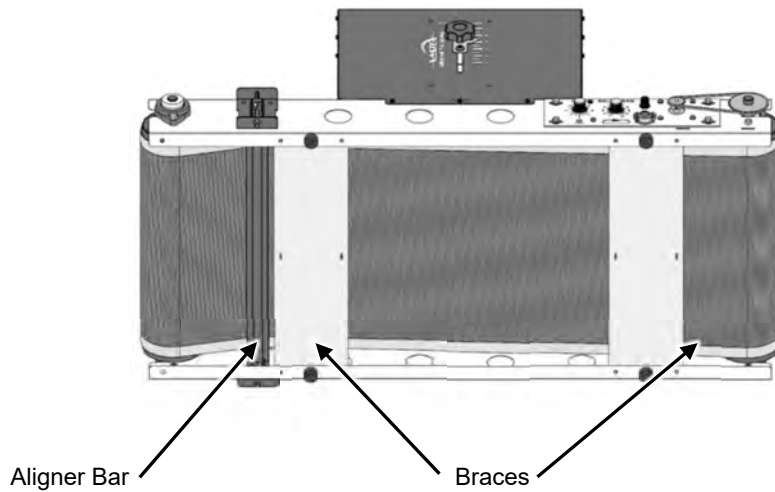

Assembly Continued

- 15) Lay the dryer back onto its feet to install the Belt. Align the Alligator Lace together and install the Belt Pin as shown, the belt dose have a top and bottom.



Alligator Lace

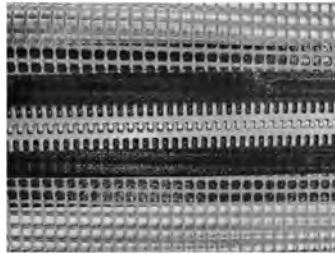

This side UP

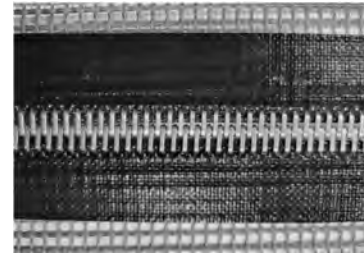

This side Down

- 16) Install Top Cover with (6) or (8) black sheet metal screws.



- 17) Install Exhaust Cover with (4) black sheet metal screws.

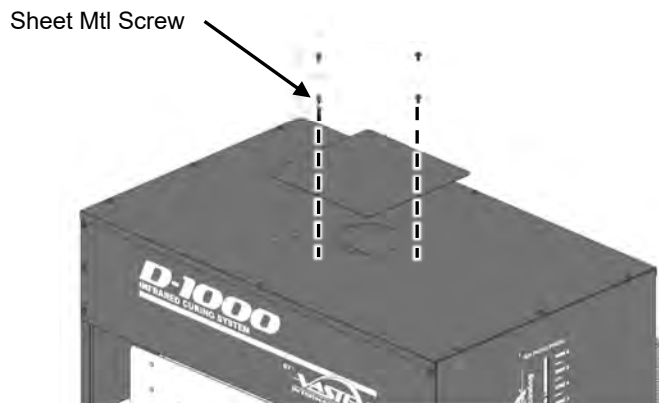

Assembly Continued

- 18)** Install the Chain Guard. Slide the chain guard into the slots on the side of the conveyor and then swing it up. Fasten it down with (2) black sheet metal screws.

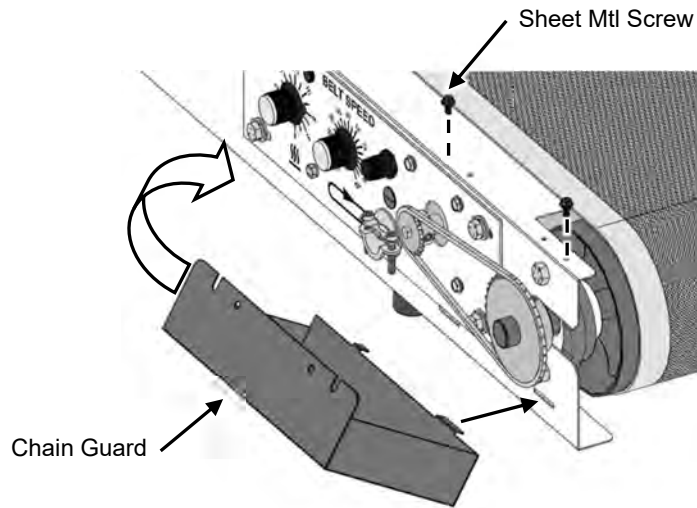

- 19)** Install a Belt Guard on each side of the rear conveyor with (2) black sheet metal screws.

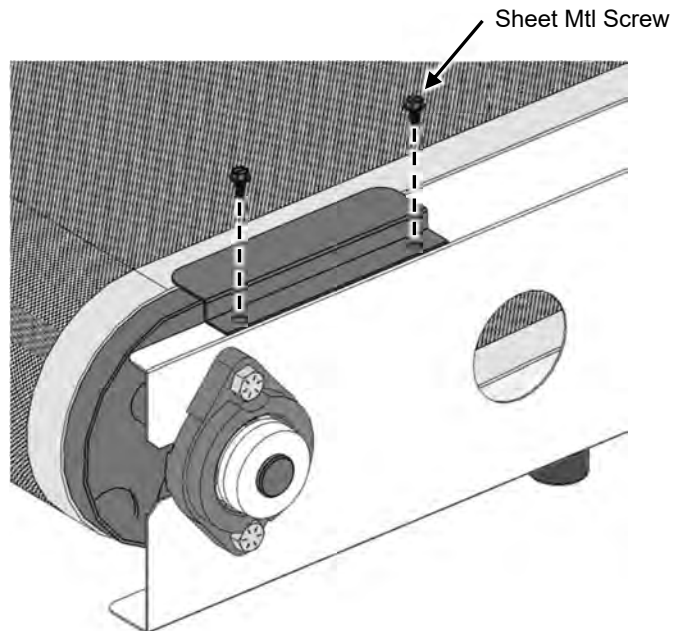

Belt Tracking

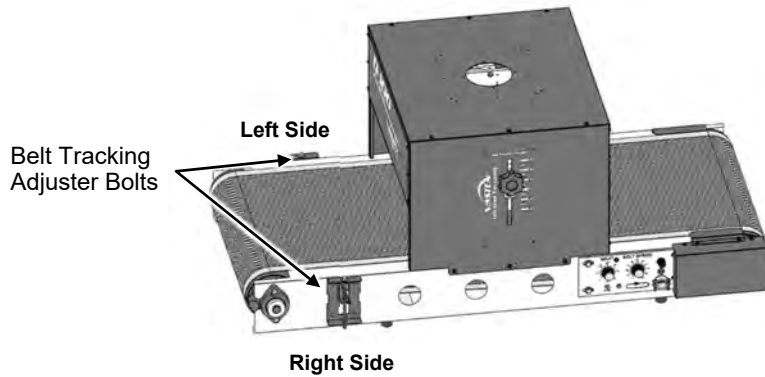

Belt Tracking

Perform after assembly is complete and dryer is on a flat surface.

Maintain belt as close to centered as possible on both rollers. Do Not leave conveyor unattended during tracking process.

- 1) While conveyor is running at full speed, observe position on both rollers.
- 2) Raising the belt aligner on one side moves the belt in the opposite direction. Lowering the bar moves the belt toward that side.
- 3) Make small adjustments, 1/4 turn of adjuster bolts. Allow the belt to respond to the adjustment.

Never allow the belt to track off the rollers, belt damage can result. Make belt tracking adjustments as needed.

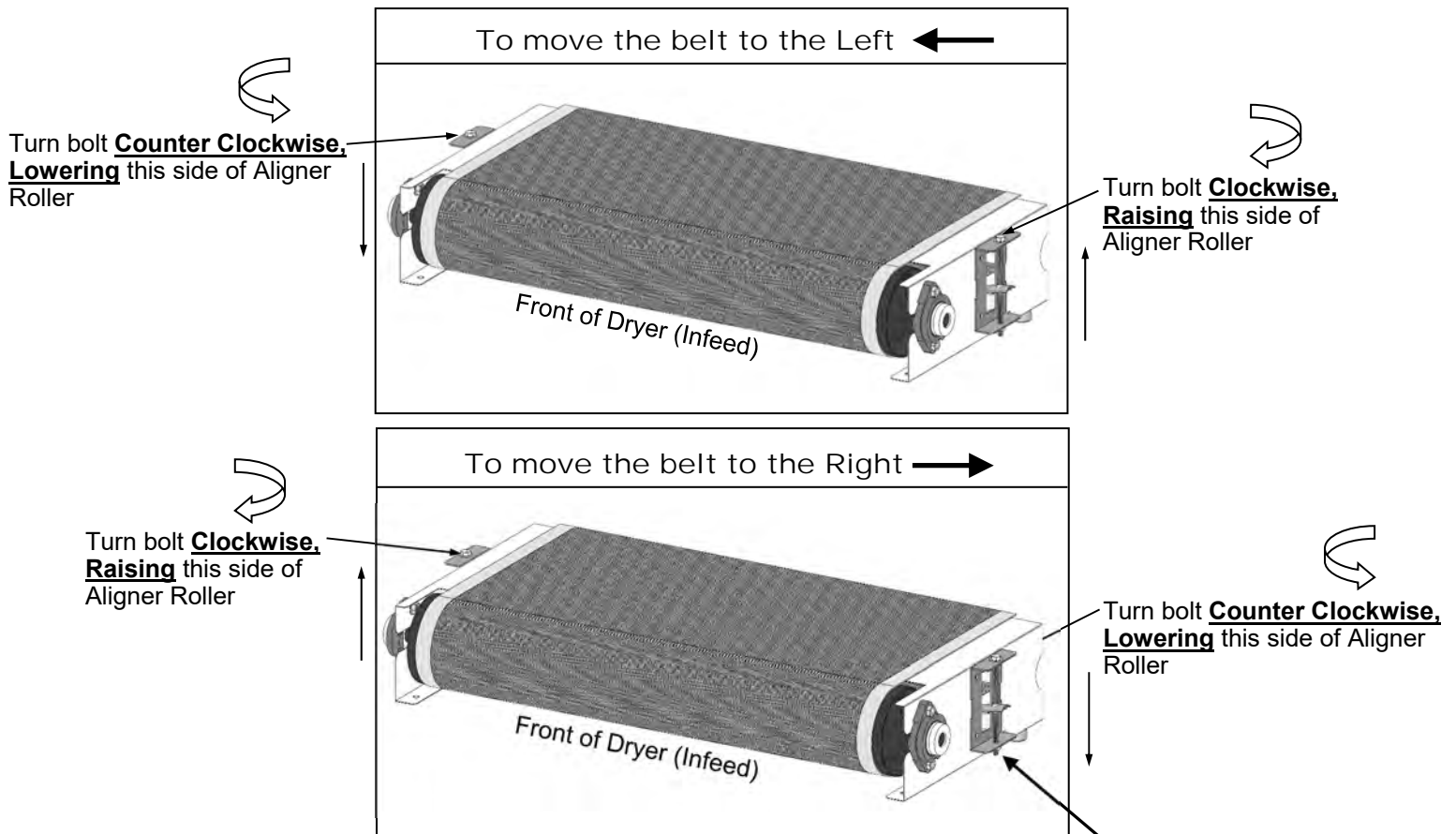

DO NOT TIGHTEN
BOTTOM NUT!

Electrical Requirements

Models: Plugs and receptacles listed are for domestic (USA) models. International models are supplied with the appropriate power cords.

D-100 / 120Volts, 12.5Amps, 1.63KW

Requires dedicated 15 amp circuit with a NEW commercial duty 5-15R receptacle.

D-1000 / 120Volts, 16.5Amps, 2.05KW

Requires dedicated 20 amp circuit with a NEW commercial duty 5-20R receptacle.

D-100-240 / 240Volts, 6.3 Amps, 1.63KW

D-1000-240 / 240Volts, 8.6 Amps, 2.05KW

Requires good quality 6-15R receptacle. (Some international plugs available)



D-100
120 Volt 15 Amps
Nema 5-15R Receptacle



D-1000
120 Volt 20 Amps
Nema 5-20R Receptacle



D-100 and D-1000
240 Volt 15 Amps
Nema 6-15R Receptacle

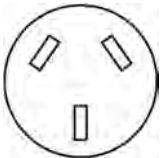

Australia Receptacle
240 Volt 10 Amps
AS/NZS 3112

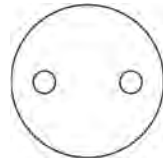

European Receptacle
240 Volt 16 Amp
CEE 7/7

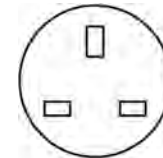

United Kingdom Receptacle
240 Volt 13 Amps
BS 1363A

Controls

- Variable Heat Control

The control has positions LO-2-3-4-5-6 and HI. The controller turns the power to the heater on and off to vary the temperature. The higher the number on the control the longer the on cycle and shorter the off cycle is. The "HI" position is full power.

- Heat On Light

This RED light is wired to the controller. It will illuminate when the control is turned on, even if the controller has failed.

- Belt Speed Control

Rotate clockwise to increase, counter clockwise to decrease belt speed.

- Fuses

Protects belt control circuit, (1) Amp AGC fast blow

One (1) fuse for 120 volt.

Two (2) fuses for 240 volt.

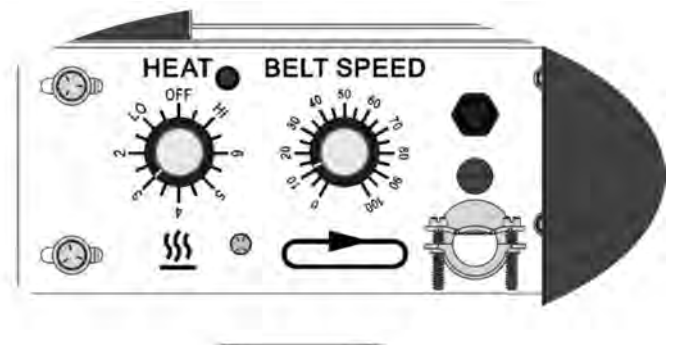

Control Plate

Dryer Operation

Startup Procedure

- 1 Plug in Dryer:** Be sure the breaker and dryer controls are switched off. Plug the dryer into a properly rated outlet and turn the breaker on.
- 2 Check belt path:** Remove any objects from the conveyor and belt.
- 3 Turn on Conveyor:** Set belt speed with the Belt Speed Control on the conveyor, near the motor.
- 4 Turn on the Heat:** Turn the Variable Heat Control dial on HI for 10-15 minutes to allow the dryer to warm up.

Curing Plastisol with infrared:

Plastisol ink can fully cure in approximately 20-30* seconds. Most inks must achieve 320°-330 F (160°-165°C) throughout to cure and fuse to the garment. The thicker the ink the hotter the top skin has to be in order to be cured completely to the garment.



Discharge or water based: (A powered exhaust is recommended)

Water based products require more time than plastisol to cure due to the fact that the water/moisture must be evaporated before the ink can cure. We have seen cure times from 50 to 90* seconds to achieve a full cure or discharge and not damage the garment. Please note as the time is increased the temperature must be decreased to protect the garment from scorching.

Direct to Film (DTF)

The process of digitally printing onto a transfer type film with a inkjet printer. The added adhesive needs to be heat set without distorting the film. Heater height: 1-2", Heat setting: 6, Belt Speed: 2-3 minutes

***Actual cure times can vary depending on conditions such as garment moisture and color, ink color, ink thickness, and environmental conditions. All three variables should be used to maximize production while insuring a proper cure.**

- 5 Set the Heat:**  With the dryer plugged in, rotate the Variable Control Timer to the desired setting. Often times, it is best to run the dryer on HI and adjust your belt speed and heater height to achieve a proper cure.
- 6 Set the Heater Height:**  Set the desired heater height for your job. On each side of the heating chamber, there is a knob to raise and lower the heater. It is recommended to run the heater height at about 2" - 3" above the garment. The heater can be run at an angle for curing non-flat sub-straight such as hats.
- 7 Set the Belt Speed:**  Rotate the Belt Speed Control Knob clockwise to increase speed and counter-clockwise to decrease it. For Plastisol inks, a good starting point is 20-25 seconds in the chamber. The dial numbers are for reference only. They do not represent seconds in the chamber.

Operation Tips

- While machine is in operation, it is necessary to have the belt moving while the heater is above 300°F (149°C).
- Allow approximately 15 minutes for dryer to reach Full temperature.
- If no garments are being run through the dryer for more than 10 minutes, it is recommended to lower the dryer heat control to "4" or lower. It will take approximately 10 minutes to return to operating temperature.
- Periodically check ink temperature at the exit of the dryer. It is recommended that you check the temperature of the ink towards the outside of the printed image.
- When checking temperature with a laser gun, shoot the ink while it is still under the heating elements.

Shut Down Procedure

- 1 Turn off Heat:** Turn the Heat Control off. Allow the heaters to cool for 10-15 minutes before shutting the conveyor off. Belt damage may result from stopping the conveyor with hot elements.
- 2 Turn off Conveyor:** Once the dryer cools down to 300°F (149°C) or lower, turn the Belt Speed down to the off position. Skip this step if leaving the conveyor belt speed set for the following shift.
- 3 Turn off Breaker:** Turn off the breaker controlling the dryers at the end of each shift and unplug them from their outlets.

— Chain Tension measured and why it is important —

The proper chain tension is critical to achieving acceptable service life as excessive tension can cause accelerated wear or chain overload and excessive slack can cause rough chain operation and possibly result in the chain skipping a sprocket tooth, resulting in a catastrophic failure. For Vastex drives, the total movement in the slack span of the chain (up and down total movement) should be .25 to .38 inch. Please see below for picture.

This is the slack in the down position.

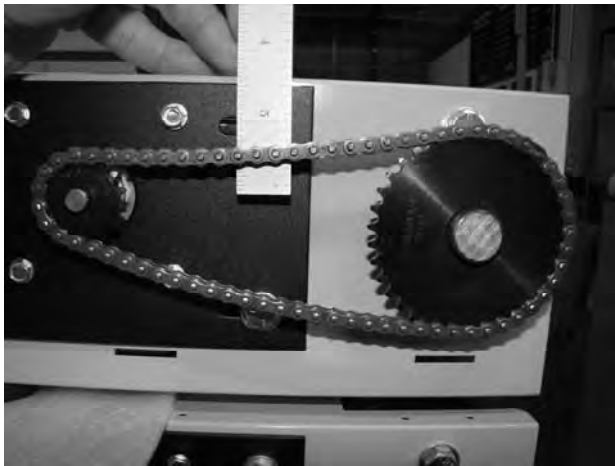

This is the slack in the up position.

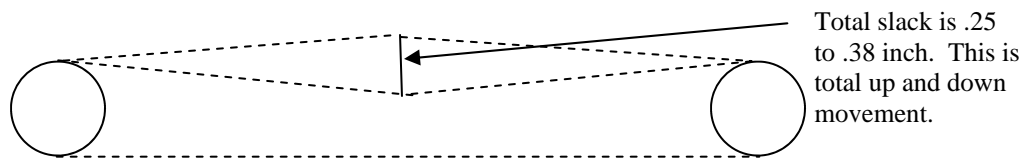
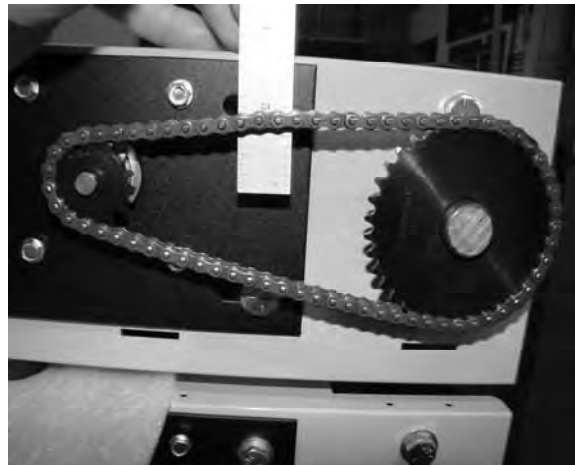

Total slack is .25 to .38 inch. This is total up and down movement.

