

## Floor Stand Assembly Instructions

### Step1

Position the support for the left side perpendicularly to bottom stand and place the screws into the holes. Tighten them to form a left side T-stand. Repeat the same steps with the support for the right side.

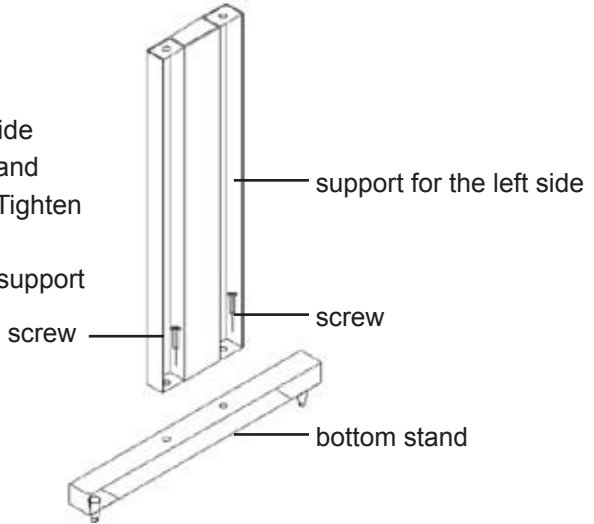

### Step2

Place the stand beam upright on the T-stand and put the screws into the holes, but do not tighten them at this step. Repeat the same steps with another stand beam.

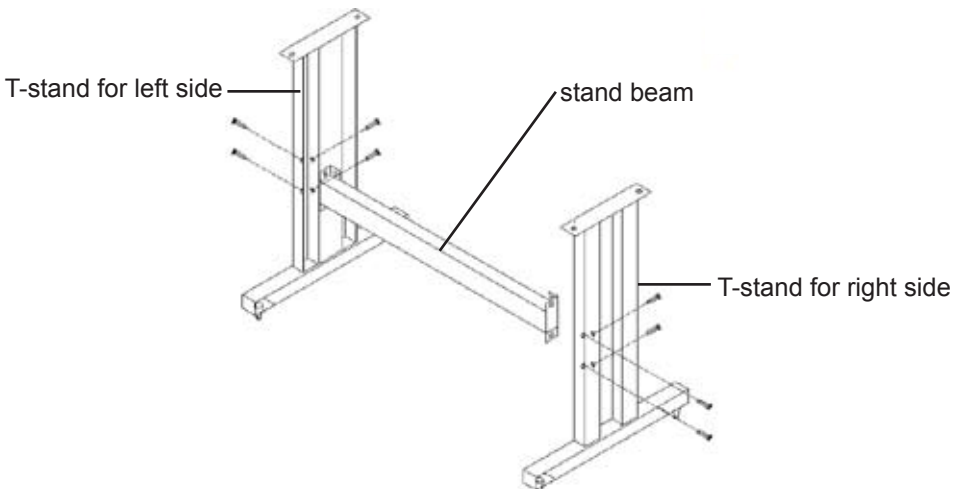

## Step3

Position the roll holder support's position to floor stand, and tighten the screws.

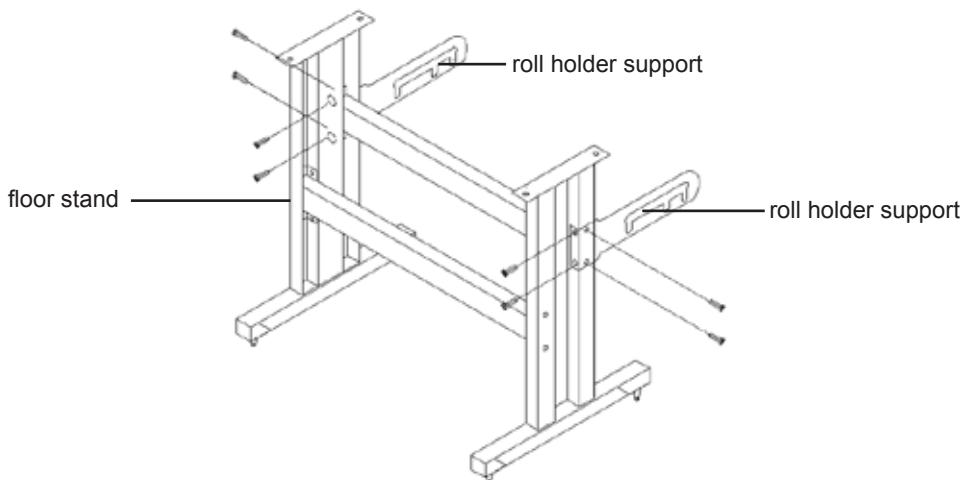

## Step4

Place two roll holders into the holes in the roll holder support.

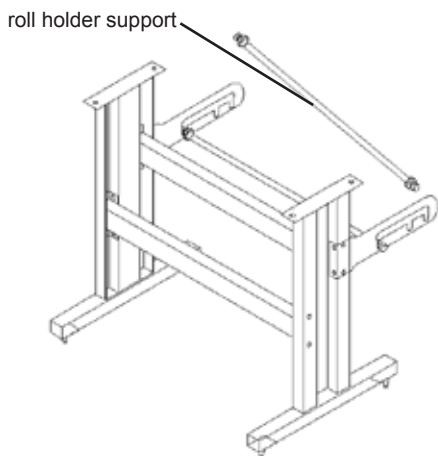

## Step5

### How to install floor stand to machine?

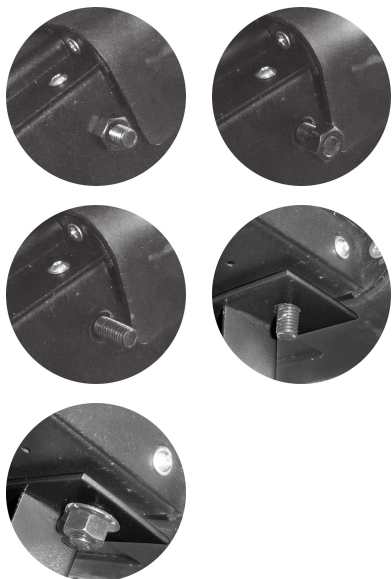

Take off the screw from bottom of machine, insert bolt to top of floor stand, then tighten the screw.