



# MID-TIER STAND SETUP

Ver. 1.3, May 2024

# TABLE OF CONTENTS

Mid-Tier Stand - Parts ..... Page 3

Mid-Tier Stand - Setup ..... Page 4-6



# MID-TIER STAND - PARTS



# MID-TIER STAND - SETUP



## Step 1:

Attach the **Crossbar (5)** to the **Leg (3)** With 2 Bolts & Washers from the **Stand Hardware** (Repeat for other side using parts 4 & 5).

Parts Needed:

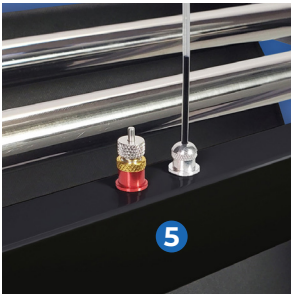

*Note: When Installing the **Crossbar (5)** the two holes in the center should face up to store extra bladeholders or the pen tool.*

## Step 2:

Attach the **Crossbar (5)** to the **Rollerbar Arm (1)** With 3 Chicago Screws from **Stand Hardware** (Repeat for other side using parts 2 & 5).

Parts Needed:

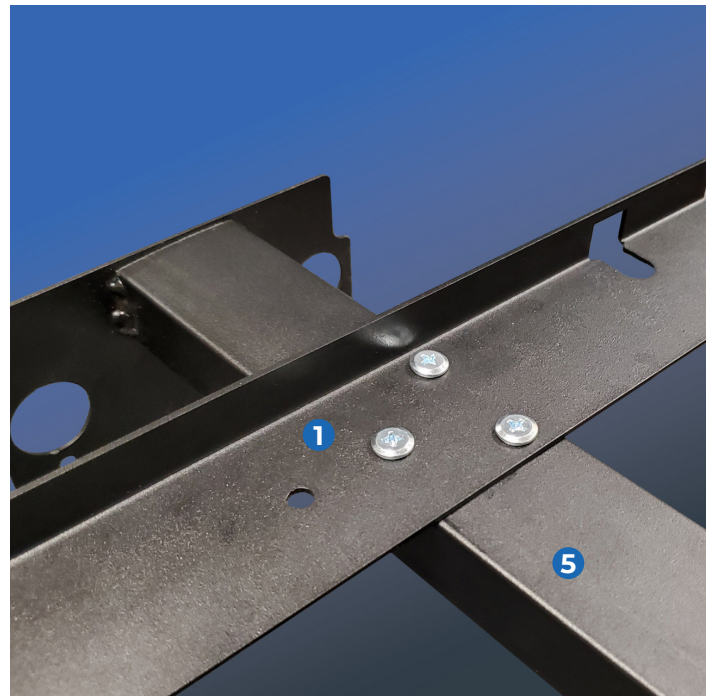

# MID-TIER STAND - SETUP (Continued)

## Step 3:

Attach the **Stand Feet (6)** to the **Leg (3)** With 2 Bolts & Washers from **Stand Hardware** (Repeat for other side using parts (4 & 6))

Parts Needed:

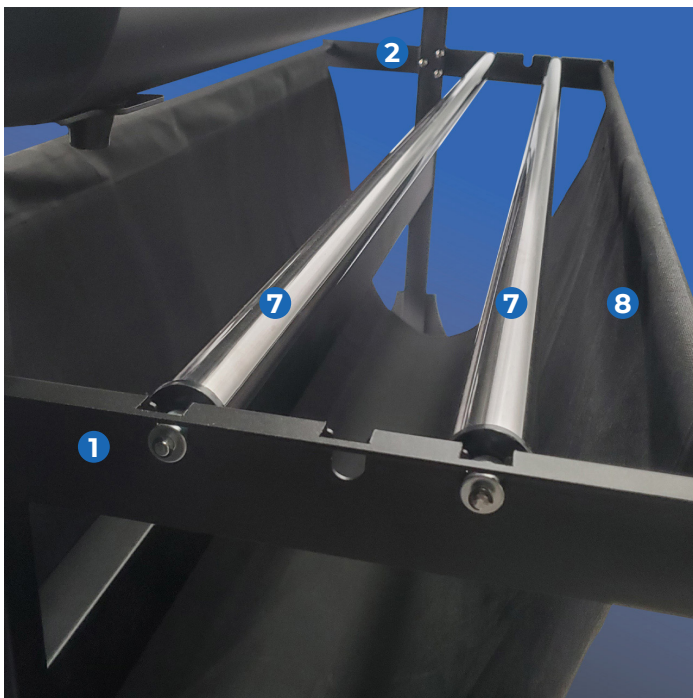
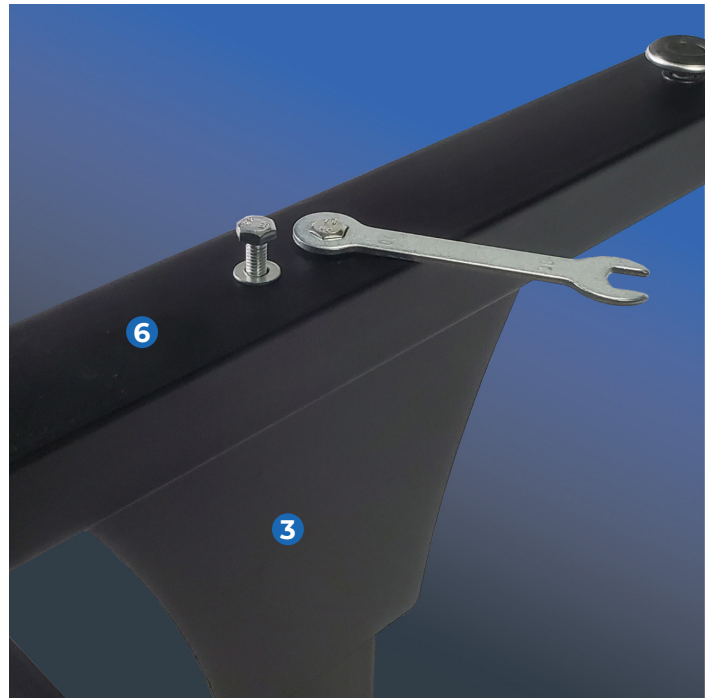

## Step 4:

Place the **Rollerbars (7)** and the **Catchbasket (8)** in the slots on the **Rollerbar Arms (1 & 2)**.

Parts Needed:



# MID-TIER STAND - SETUP (Continued)



## Step 5:

Place the vinyl cutter feet into the corresponding holes on the **Stand Legs (3 & 4)** and secure using 4 screws from the **Stand Hardware**.

Parts Needed:



x4

## Finished:

You now have a completed your **Mid-Tier Stand** with vinyl cutter attached.

- 1 Right Rollerbar Arm
- 2 Left Rollerbar Arm
- 3 Right Leg
- 4 Left Leg
- 5 Crossbar
- 6 Stand Feet
- 7 Rollerbars
- 8 Catchbasket

