

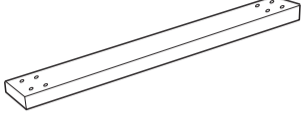

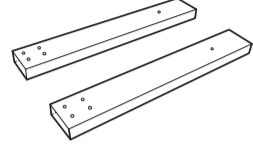
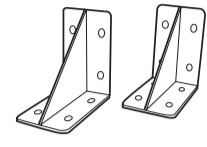
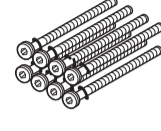

Accessories

A  Stay: 1	C  Stand legs: 2	E  Mounting fixtures: 2	G  Screws with washers: 8 (for stand assembly)	I  Screws with washers: 16 (for mounting fixtures)	K  Screws : 10 (for installing the sheet hangers and unit)
B  Caster flats: 2	D  Stoppers: 2 Shafts: 2	F  Sheet hangers: 2	H  Caps: 8 (for G screws)	J  (Large) (Small) Hexagonal wrenches: 2	

Assembly Instructions

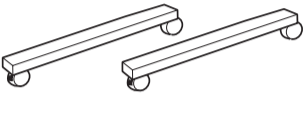
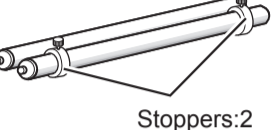
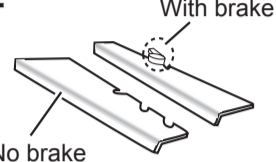
- ⚠ CAUTION** Unpacking, installation, and moving must be carried out by two or more persons. Failure to do so may result in falling of the unit, leading to injury.
- ⚠ CAUTION** Use the joining screws to secure the unit to the stand. Failure to do so may result in falling of the unit, leading to injury.
- ⚠ CAUTION** Use care to avoid pinching the fingers when placing the unit on the stand. Doing so may result in injury.

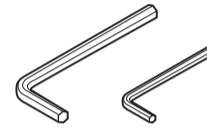
- 1**
 - ① Assemble the caster flats (B) and the stay (A).
 - ② Tighten the screws (G), then attach the caps (H).
 - Use four screws (G) and the large hexagonal wrench (J).
 - Orient the stay (A) so that the surface with eight holes faces up.
 - Assemble the caster flats (B) and the stay (A) with the side of each caster flat (B) that has small holes touching the ends of the stay (A).
 - Tighten the screws (G) so that they are finger-tight, then place on a flat surface and tighten the screws completely.

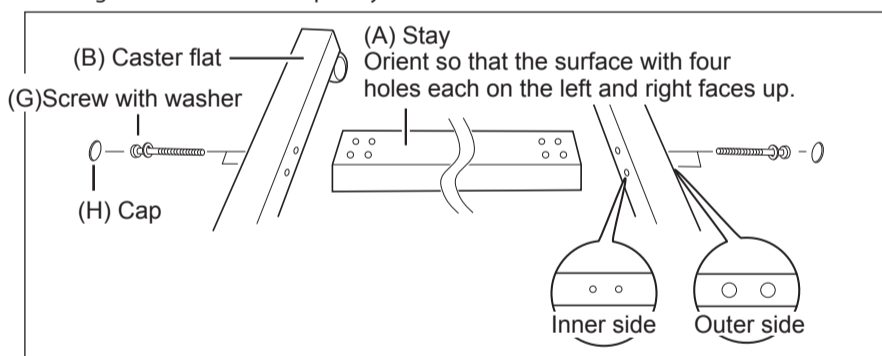

- 2** Attach the stand legs (C) to the caster flats (B).
 - Each stand leg (C) has an inner side and an outer side. (See the figure below.)
 - Tighten all screws to finger-tight.
 - Use the mounting fixtures (E), the screws (I), and the large hexagonal wrench (J).

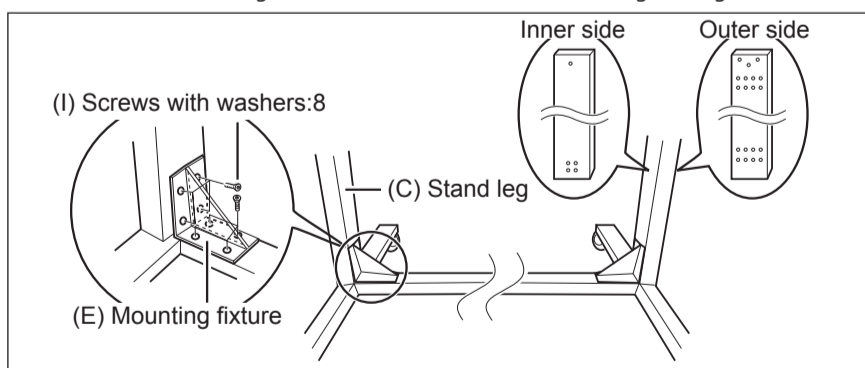

- 3**
 - ① Turn the stand legs you assembled in step 2 upside-down.
 - ② Use four screws (G) to install in the holes on the bottom surfaces of the caster flats (B). Securely tighten all finger-tight screws (including the screws loosely tightened in step 2), then fit on the caps.
 - Use four screws (G) and the large hexagonal wrench (J).

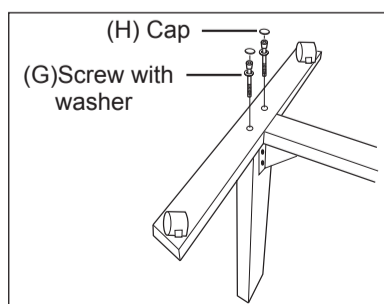

- 4** Temporarily remove the brake from the sheet hanger (F).
 - Use the small hexagonal wrench (J).

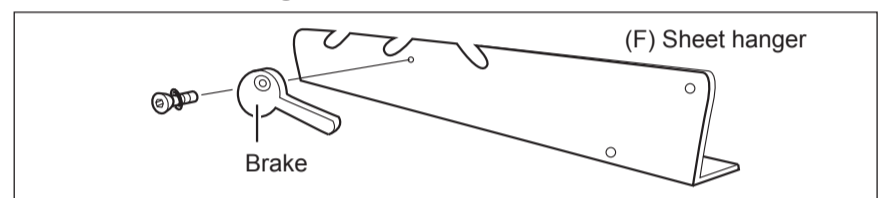

- 5**
 - ① Attach the sheet hangers (F) from the outer sides of the stand legs (C). Orient so that the bent portions face outward.
 - ② Install the shafts (D).
 - ③ Attach the brake you removed in step 4.
 - Use four screws (K) and the small hexagonal wrench (J).
 - The left and right sheet hangers are different. Attach the sheet hanger that is provided with the brake to the left side.
 - Arrange the shaft with no stopper on the inner side and the shaft with a stopper on the outer side.

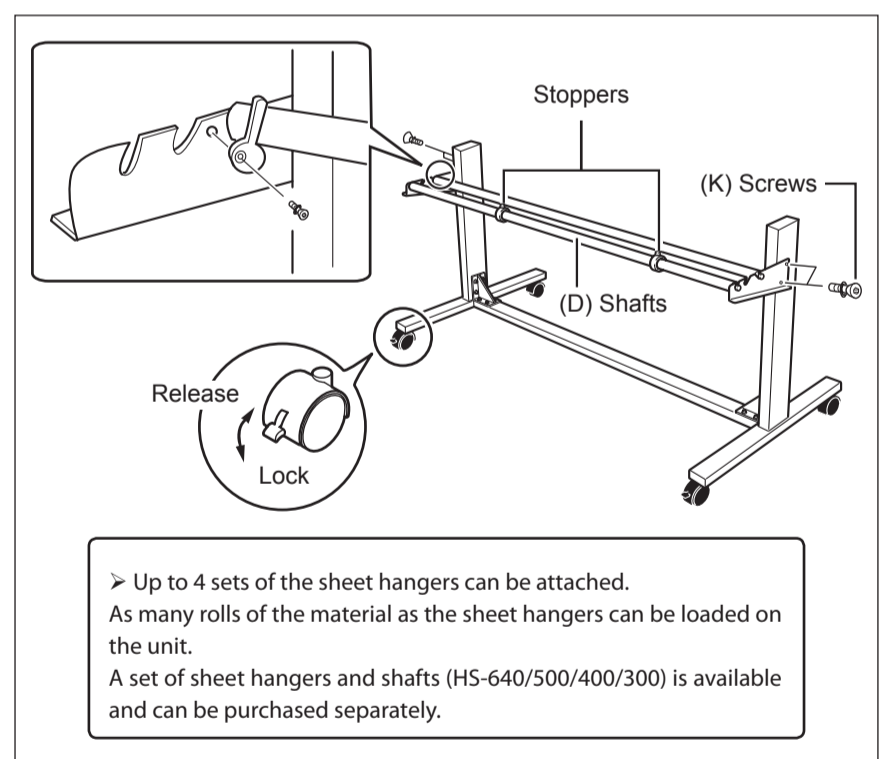

- 6** Mount the unit on the stand.
 - Use six screws (K) and the small hexagonal wrench (J).
 - Place the stand with the shafts on the rear side, and mount the unit on the stand.

